

SIGNAL ISOLATOR, DUAL OUTPUT

SI4P

REPEATER POWER SUPPLY, 4 ~ 20 mA, FOR 2-WIRE TRANSMITTER WITH 1 OR 2 4~20 mA OUTPUTS

REPEATER POWER SUPPLY, 0/4 ~ 20 mA, FOR CURRENT SOURCE WITH 1 OR 2 0/4~20 mA OUTPUTS



- Mutual isolation between input, output1, output2 and power supply
- Provides two outputs from one 4 to 20 mA transmitter or one 0/4~20 mA current source
- Line fault detection feature provides alarm facilities
- Transfer accuracy <0.1% of span
- 17~35 V DC / 85~265 V AC power supply
- T section DIN Rail mounting
- Input protection option

SI4P is an independently powered isolator which provides both a fully isolated DC supply for energising a 2-wire transmitter while also transferring the transmitter current to two separate isolated output circuits driving loads upto 1 kΩ. The input can also be a 0/4~20 mA current source. Line fault detection feature (also isolated) is provided by an open collector which can be used to activate an alarm. When the input cable is broken, no current flows into terminal 2/3 and the line fault detection (LFD) output is OFF. When a current greater than 1 mA flows in the input, then LFD output is ON. Power supply required is 17~35 V DC / 85~265 V AC. An input protection option is also provided.

SPECIFICATIONS All specifications at ambient of 25 °C, unless specified otherwise

No. of input channels	One	Supplying a transmitter (0~20mA input)	180 mA maximum at 20 V DC with a 20 mA signal 130 mA maximum at 35 V DC with a 20 mA signal
Input channel	2-wire transmitter supply, 4~20 mA OR 4~20 mA current source OR 0~20 mA current source	From a current source (0~20mA input)	150 mA maximum at 20 V DC with a 20 mA signal 105 mA maximum at 35 V DC with a 20 mA signal < 5 VA
No. of output channels	Two	For A = 01*	
Input/output signal	4~20 mA OR 0~20 mA If 0~20 mA input is ordered, it will work for 4~20 mA. However, the power requirement is higher.	Transfer accuracy at 25 °C for both outputs 4~20 mA 0~20 mA	< ± 0.1% of span Better than 16 μA Better than 20 μA
Load resistance, each output	0 ~ 1 kΩ	Line fault detection (LFD) output	Isolated transistor open collector output
Mutual isolation between input, output 1, output 2 and power supply	1500 V AC RMS, 1 minute	LFD characteristics Input current < 0.2 mA	Transistor OFF Max permitted voltage : 26 V DC Max OFF leakage current : 150 μA
Voltage available for transmitter	20 V typical at 20 mA	Input current > 1 mA	Transistor ON Max permitted input current : 50 mA Max ON voltage : 1V
Voltage drop across input from current source Without protection With protection	1.5 V maximum 3.0 V maximum	Temperature coefficient of accuracy	< 0.02% of span / °C
Input protection Against overvoltage Against overcurrent	30 V DC maximum 50 mA maximum	Common mode rejection ratio	150 dB typical
Power supply	a) 85~265 V AC, 50/60 Hz OR b) 17~35 V DC	Ambient temperature limits	-20 °C to +55 °C (operating) -40 °C to +80 °C (storage)
Power consumption For A = 00* Supplying a transmitter (4~20mA input)	140 mA maximum at 20 V DC with a 20 mA signal 100 mA maximum at 35 V DC with a 20 mA signal	Humidity	5 ~ 95% RH, non-condensing
From a current source (4~20mA input)	115 mA maximum at 20 V DC with a 20 mA signal 80 mA maximum at 35 V DC with a 20 mA signal	Enclosure Material Dimensions Mounting	ABS plastic 75(H) x 45(W) x 110(D) mm 75(H) x 55(W) x 110(D) mm Snap on for 35 mm DIN rail to DIN 46277
		Terminals Weight Protection	Accomodate 2.5 mm ² conductors < 250 grams IP 20

* = See Ordering Information

REPEATER POWER SUPPLY, 4 ~ 20 mA, FOR 2-WIRE TRANSMITTER WITH 1 OR 2 4~20 mA OUTPUTS

REPEATER POWER SUPPLY, 0/4 ~ 20 mA, FOR CURRENT SOURCE WITH 1 OR 2 0/4~20 mA OUTPUTS

CONNECTION DIAGRAM

Supply voltage : 17~35 V DC

* - Use terminal 3 (input protection absent) instead of terminal 2 for lower input voltage drop

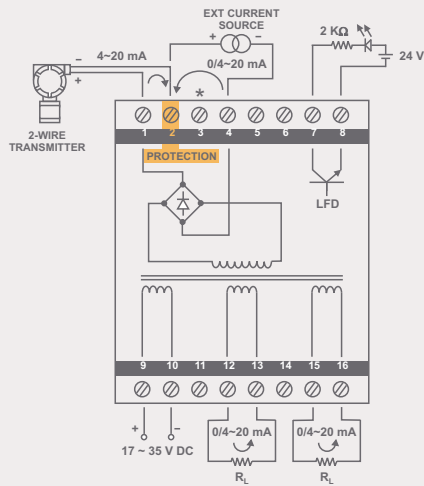

Supply voltage : 85~265 V AC

* - Use terminal 3 (input protection absent) instead of terminal 2 for lower input voltage drop

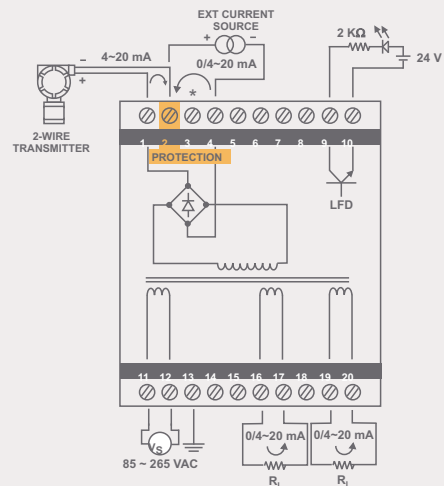

ORDERING INFORMATION

SI4P will be supplied with the following standard specifications :

No. of outputs	2
Input type	4~20 mA

ORDER CODE	
2051	A

A	Supply voltage
00	17 ~ 35 V DC
01	85 ~ 265 V AC, 50/60 Hz

Ordering Options

The following ordering options are available on request. Minimum order quantity and/or minimum order value may apply.

	Option details
1.	0 ~ 20 mA input/output
2.	1 output



RADIX ELECTROSYSTEMS PVT LTD
 B-14, 2nd Floor, Ghanshyam Indl Estate
 Veera Desai Road, Andheri (West)
 Mumbai - 400 053, India
 + 91 22 42537777 | sales@radix.co.in

OTHER ENQUIRIES

Instruments sales@radix.co.in
Sensors sensors@radix.co.in
Gauges gauges@radix.co.in
Automation automation@radix.co.in