

RE-717MX

ADDRESSABLE INPUT OUTPUT MODULE

General

Addressable Input Output Module with dual address is a combination of relay module and monitor module. The device shall be programmed for various correlation as independent devices. The RED blinking LED indicates normal operating conditions and the steady state LED for activated conditions. DIP switches are provided for addressing of the module.

Features

- Complies UL standard
- CE Approved.
- Dual Address
- Module Status by RED LED.
- Analogue Communication with the panel.
- Addressing by 8 way DIP switches.
- Available with suitable back boxes.
- Low Standby Current.



Specification

Electrical Specification	
<i>Operating Voltage</i>	24 VDC Nominal
<i>Alarm Current</i>	2.7 mA Max.(Latched)
<i>Standby Current</i>	0.7 mA
<i>Contact Rating</i>	2A @ 30VDC(Resistive)
<i>End of Line Resistor</i>	47K Ohms
<i>Loop Impedance</i>	40 Ohms
<i>IDC wiring Resistance</i>	100 Ohms Max
<i>IDC Voltage</i>	8 V Max
<i>Temperature Range</i>	0°C to 49°C / 32°- 120°F
<i>Storage Temperature</i>	0°C to 60°C
<i>Humidity</i>	93 ± 2% RH (non-condensing) at 32 ±2° C / 90 ±3° F
Mechanical Specification	
<i>Dimensions</i>	(95 W X 75 H X 24 D) mm
<i>Color</i>	Black
<i>Weight</i>	0.35 Kg

Dimensions

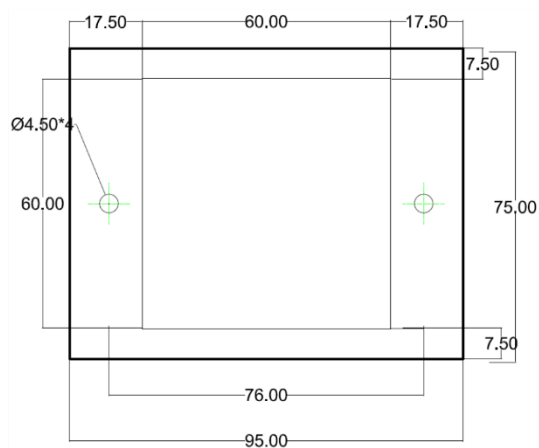
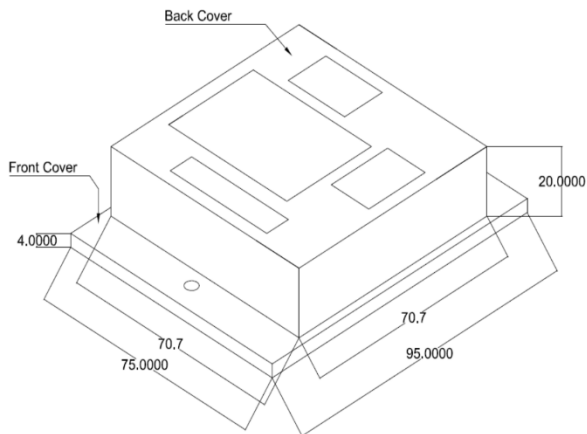

Wiring Configuration

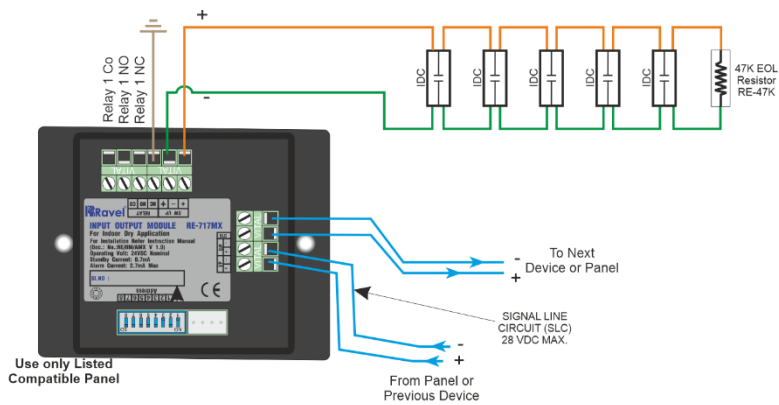

Compatible Device

Model	Description
<i>Avani</i>	Analogue addressable Fire Alarm Control panel expandable upto 4 loop
<i>Avani db</i>	Analogue Addressable Fire Alarm Control panel expandable upto 2 loop
<i>Avani XL</i>	Analogue Addressable Fire Alarm Control Panel expandable upto 8 Loop

Ordering Information

Models	Description
RE-717MX	Addressable Input Output Module

India

RAVEL ELECTRONICS PVT LTD.,
150A, Electronics Industrial Estate,
Perungudi, Chennai – 96, India.
E-mail: marketing@ravelfire.com; Web: www.ravelfire.com

United Kingdom

RAVEL ELECTRONICS LTD.,
Unit 11, Chancel Industrial Estate, Newhall street,
Willenhall WV13 1NX, West Midlands, United Kingdom.
E-mail: info@ravelfire.co.uk; Web: www.ravelfire.co.uk

USA

RAVEL AMERICAS INC.,
2855 NW 112th Ave ST#2 Miami,
Doral, Florida 33172, USA.