

RE-717MR

ADDRESSABLE RELAY MODULE

General

Relay Module is an output module facilitates dual form C potential free contact to integrate the third party devices with Fire Alarm Control panels like lift, pressure fan, access control etc. The RED blinking LED indicates normal operating conditions and the steady state LED for activated conditions. DIP switches are provided for addressing of the module.

Features

- UL-Listed (9th Edition).
- CE Approved.
- Module Status by RED LED.
- Dual Form C Potential free contacts.
- Non supervised Output
- Analogue Communication with the panel.
- Addressing by 8 way DIP switches.
- Low Standby Current.
- Available with suitable back boxes.
- Modular Construction.

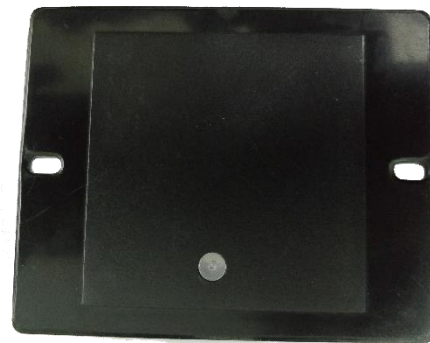

Specification

Electrical Specification	
Operating Voltage	24 VDC Nominal.
Current Draw	2 mA Max.(Latched)
Standby Current	0.5 mA
Contact Rating	2A @ 30VDC(Resistive)
Operating Temperature	0°C to 49°C / 32° - 120°F
Storage Temperature	0°C to 60°C
Humidity	93 ± 2% RH (non-condensing) at 32 ± 2° C / 90 ± 3° F
Mechanical Specification	
Dimensions	(95 W X 75 H X 24 D) mm
Color	Black
Material	FR ABS plastic
Weight	0.35 Kg

Dimensions

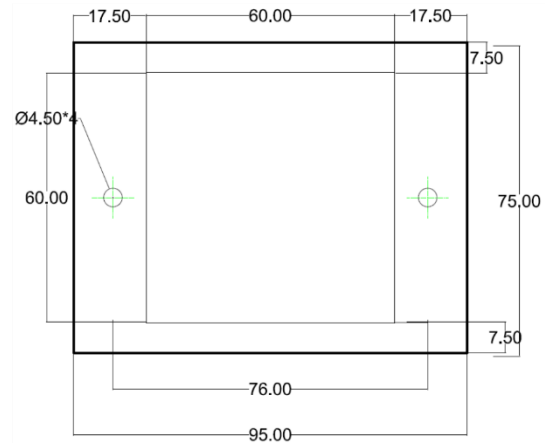
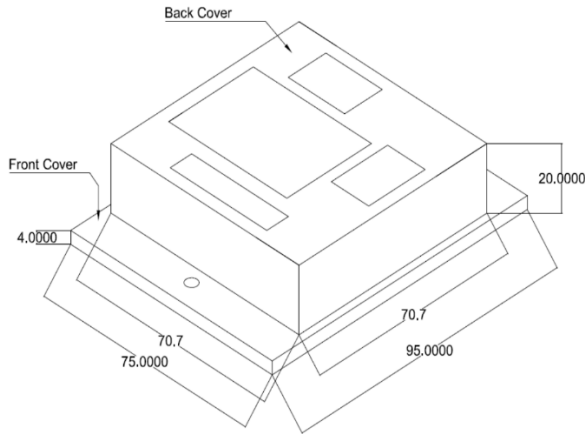

Wiring Configuration

Use only Listed Compatible Panel

Relay 2 Co
Relay 2 No
Relay 2 Nc
Relay 1 Co
Relay 1 No
Relay 1 Nc

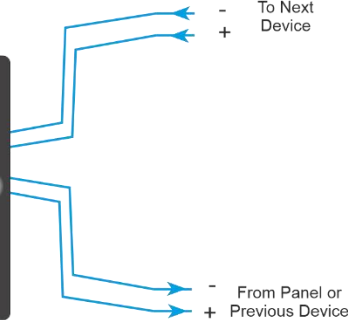
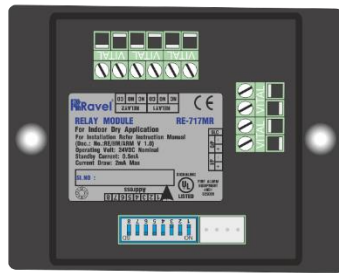

NOTE:

- * ALL WIRING SHOWN IS SUPERVISED AND POWER LIMITED
- * RELAY OUTPUT ARE NOT SUPERVISED

Compatible Device

Model	Description
<i>Avani</i>	Analogue addressable Fire Alarm Control panel expandable upto 4 loop
<i>Avani db</i>	Analogue Addressable Fire Alarm Control panel expandable upto 2 loop
<i>RE-4100</i>	Analogue Addressable Fire Alarm Control panel expandable upto 4 loop
<i>Avani XL</i>	Analogue Addressable Fire Alarm Control Panel expandable upto 8 Loop

Ordering Information

Models	Description
RE-717MR	Addressable Relay Module

India

RAVEL ELECTRONICS PVT LTD.,
150A, Electronics Industrial Estate,
Perungudi, Chennai – 96, India.
E-mail: marketing@ravelfire.com; Web: www.ravelfire.com

United Kingdom

RAVEL ELECTRONICS LTD.,
Unit 11, Chancel Industrial Estate, Newhall street,
Willenhall WV13 1NX, West Midlands, United Kingdom.
E-mail: info@ravelfire.co.uk; Web: www.ravelfire.co.uk

USA

RAVEL AMERICAS INC.,
2855 NW 112th Ave ST#2 Miami,
Doral, Florida 33172, USA.