

# RE-717MM

## ADDRESSABLE MONITOR MODULE

### General

Monitor Module is an input module facilitates to interface with third party devices like security contacts, waterflow switches, pull stations, etc. with Fire Alarm Control Panel. The RED blinking LED indicates normal operating conditions and the steady state LED for activated conditions. DIP switches are provided for addressing of the module. The Monitor circuit is supervised for faulty condition.



### Features

- UL-Listed (9th Edition).
- CE Approved.
- Modular Construction.
- Module Status by RED LED.
- Analogue Communication with the panel.
- Addressing by 8 way DIP switches.
- Low Standby Current.
- Available with suitable back boxes.

### Specification

Electrical Specification	
<b>Operating Voltage</b>	24 VDC Nominal.
<b>Alarm Current</b>	2.7 mA Max.(Latched)
<b>Standby Current</b>	0.7 mA
<b>End of Line Resistor</b>	47K Ohms
<b>Loop Impedance</b>	40 Ohms
<b>IDC wiring Resistance</b>	100 Ohms Max
<b>IDC Voltage</b>	8 V Max
<b>Operating Temperature</b>	0°C to 49°C / 32°- 120°F
<b>Storage Temperature</b>	0°C to 60°C
<b>Humidity</b>	93 ± 2% RH (non-condensing) at 32 ±2° C / 90 ±3° F
Mechanical Specification	
<b>Dimensions</b>	(95 W X 75 H X 24D) mm
<b>Color</b>	Black
<b>Material</b>	FR ABS plastic
<b>Weight</b>	0.35 Kg

## Dimensions

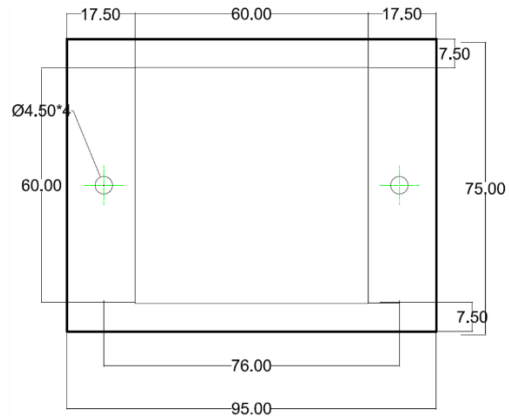
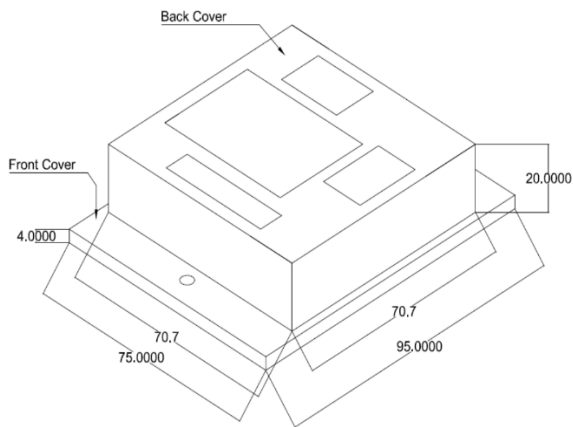

## Wiring Configuration

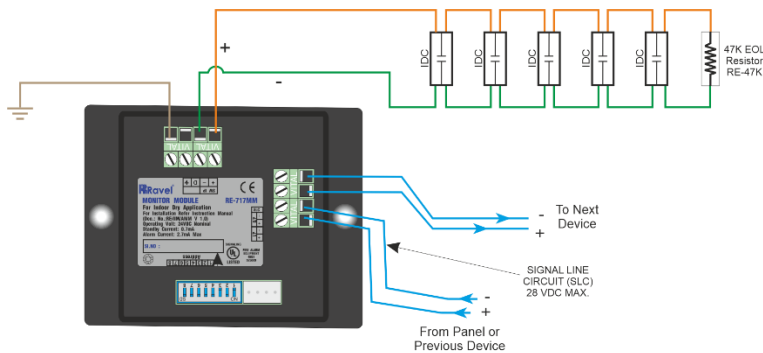

Use only Listed Compatible Panel

### NOTE:

\* D = NO CONNECTION

\* ALL WIRING SHOWN IS SUPERVISED AND POWER LIMITED

## Compatible Device

Model	Description
<i>Avani</i>	Analogue addressable Fire Alarm Control panel expandable upto 4 loop
<i>Avani db</i>	Analogue Addressable Fire Alarm Control panel expandable upto 2 loop
<i>Avani XL</i>	Analogue Addressable Fire Alarm Control Panel expandable upto 8 Loop

## Ordering Information

Models	Description
RE-717MM	Addressable Monitor Module

### India

RAVEL ELECTRONICS PVT LTD.,  
150A, Electronics Industrial Estate,  
Perungudi, Chennai – 96, India.  
E-mail: [marketing@ravelfire.com](mailto:marketing@ravelfire.com); Web: [www.ravelfire.com](http://www.ravelfire.com)

### United Kingdom

RAVEL ELECTRONICS LTD.,  
Unit 11, Chancel Industrial Estate, Newhall street,  
Willenhall WV13 1NX, West Midlands, United Kingdom.  
E-mail: [info@ravelfire.co.uk](mailto:info@ravelfire.co.uk); Web: [www.ravelfire.co.uk](http://www.ravelfire.co.uk)

### USA

RAVEL AMERICAS INC.,  
2855 NW 112<sup>th</sup> Ave ST#2 Miami,  
Doral, Florida 33172, USA.