

# RE-24LS

## ADDRESSABLE LOOP POWERED SOUNDER

### General

The addressable Loop powered sounder are designed to be connected to analogue addressable Fire Alarm Systems. And these loop powered sounder should be connected to the compatible control panel. The addressable loop powered sounder receives their power from analogue addressable communication loop and it is controlled via addressable communication. The address of these device should be in the range of 128 to 159 addresses and it shall be set by 8 way DIP Switch.

### Features

- Addressing by 8 way DIP switch.
- Low Standby Current.
- Slim and Sleek.
- 8 Different tone selection by using 4 way DIP Switch.
- Wall or Ceiling Mount.
- Inbuilt Isoaltor



### Specification

	Electrical Specification
<i>Operating Voltage</i>	17 ~ 32 VDC
<i>Operating Current</i>	9 ± 5 mA
<i>Standby Current</i>	0.5 mA
<i>Sound Level</i>	90 ± 5 db @ 1m
<i>Operating Temperature</i>	0 - 49° C / 32 - 120° F
<i>Storage Temperature</i>	0 – 60° C
<i>Relative Humidity</i>	≤ 95% ± 2% RH (non-condensing) at 32 ± 2° C / 90 ± 3° F
<i>Sounder Type</i>	Piezo Electric Type
<i>Tone Type</i>	8 Different Types
<i>Material</i>	ABS Plastic
<i>Color</i>	Red
<i>Mount Type</i>	Surface Mount/Flush mount
<i>Dimensions</i>	95H X 75L X 28D in mm
<i>Back Box</i>	95H X 75L X 58D in mm

## Wiring Diagram

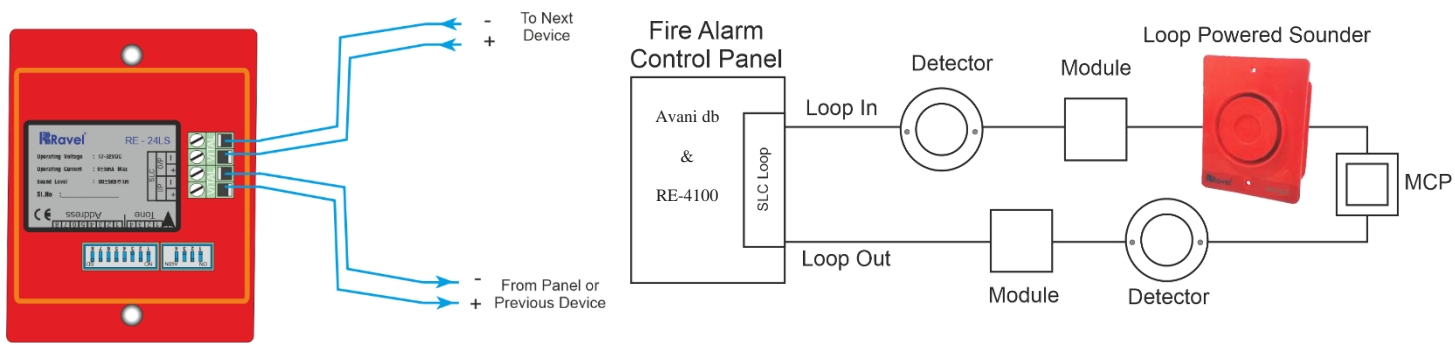

Connect the Loop Positive & Negative wires to SLC IN Terminal, observing the polarity. The wiring Terminal accepts solid or stranded cables up to 2.5 mm<sup>2</sup>.

## Tone Selection Chart

Tone	Description
1	Dutch sweep tone @ 970 Hz continuous
2	Din Tone 1200Hz falling to 500Hz over 1 sec
3	French Fire Sound 554Hz for 100ms and 440Hz for 400ms
4	Alternative warble BS standard 800/960 Hz @ 2 Hz
5	US temporal pattern HF 2900 Hz for 0.5s on 0.5s off x 3 then 1.5s off
6	Sweep 800-1000 hz @ 0.5 sec
7	Siren high freq sweep 500-1000 in 0.5 sec
8	Siren low freq sweep 500-1000 in 1.5 sec

## Compatible Panel

Model	Description
<i>Avani db</i>	Analogue Addressable Fire Alarm Control Panel expandable upto 2 Loop
<i>RE-4100</i>	Analogue Addressable Fire Alarm Control Panel expandable upto 4 Loop

## Ordering Information

Model	Description
RE-24LS	Addressable Loop Powered Sounder

### India

RAVEL ELECTRONICS PVT LTD.,  
150A, Electronics Industrial Estate,  
Perungudi, Chennai – 96, India.  
E-mail: [marketing@ravelfire.com](mailto:marketing@ravelfire.com); Web: [www.ravelfire.com](http://www.ravelfire.com)

\*Ravel reserve the right to change the specification without prior notice.

### United Kingdom

RAVEL ELECTRONICS LTD.,  
Unit 11, Chancel Industrial Estate, Newhall street,  
Willenhall WV13 1NX, West Midlands, United Kingdom.  
E-mail: [info@ravelfire.co.uk](mailto:info@ravelfire.co.uk); Web: [www.ravelfire.co.uk](http://www.ravelfire.co.uk)

### USA

RAVEL AMERICAS INC.,  
2855 NW 112<sup>th</sup> Ave ST#2 Miami,  
Doral, Florida 33172, USA.